

FQ2 Smart Camera

The New Standard for Image Inspection



» Advanced inspection in a compact housing

» Expanded performance and functionality

» Camera, Communications, Software Tools, and Much More

Introducing the Smart Heavyweight

Inspection capabilities, camera options, and communication options -- this powerful heavyweight has it all.

This Vision Sensor provides all of the best-selling features found in high-end models without the need for a separate controller.

This new Smart Camera was designed to entice all potential customers to try out the FQ2 Series.



High-speed image processor	Megapixel capacity	Real color	Monochrome	C-mount	9 inspection items	11 image filters	32 -camera expansion	360° position compensation	Ultra-wide field of view	DAP partial input
HDR	Sub-pixel processing	High-power lighting	IP67	E-IP	PLC Link	FINS	34 I/O points	RS-232C	Password	Image inversion

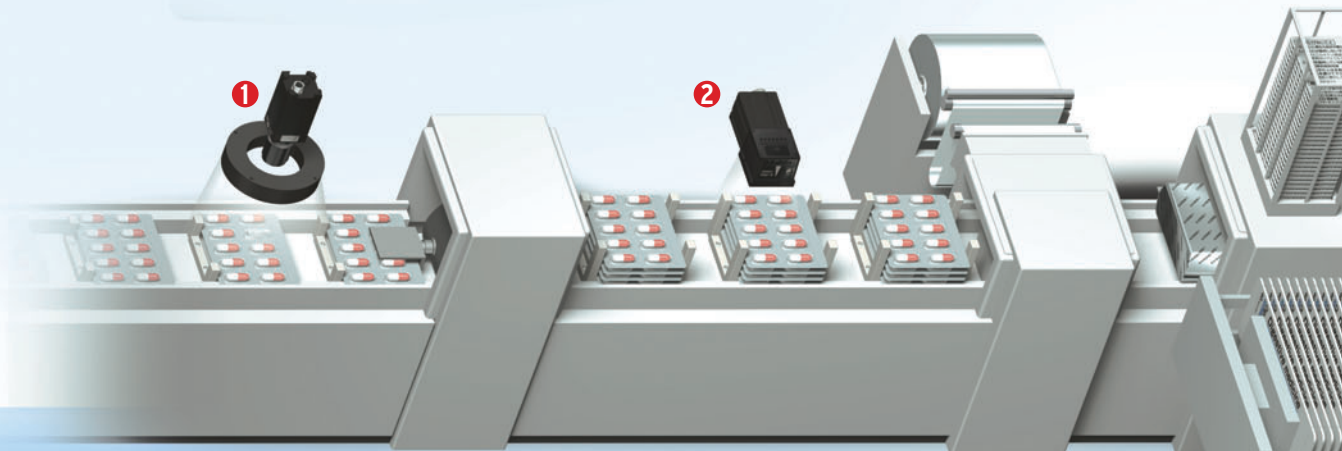

① Missing Pill



② Misalignment



③ Package Insert Detection

Three Improvements for Smoother Device Design

Compact Body

All in one Vision Sensor

All-in-one compact size that is perfect for use in tight spaces or as an aftermarket option. Compared to more-advanced Vision Sensors with multiple components, this Sensor boasts a much more efficient hardware design.

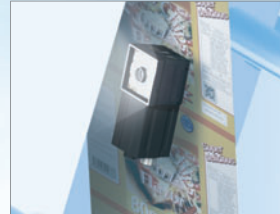

» p.04

Extended Functions

Easily Perform Both Inspection and Positioning

This Sensor contains all of OMRON's inspection algorithms in one compact package. Try out the Smart Camera to experience many inspection and positioning features found on more expensive Vision Sensors. There is no need to use different Vision Sensors for different processes, which greatly reduces the amount of time required to select the right Vision Sensor for the job.

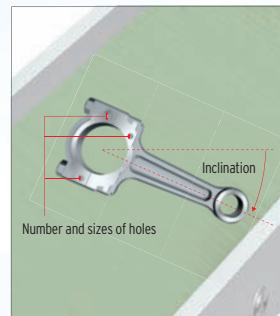

» p.06

Diverse Lineup

A Lineup That Fits a Wide Range of Equipment

Expanded inspection menu, camera variations, and communication interfaces with the same pricing level as our previous FQ Series.

This Sensor lineup provides a wide range of options that enables application as a standard image inspection device.



» p.08

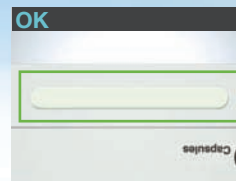

4 Hot-melt Detection



5 Tape Detection and Character Detection

Compact

All in one Vision Sensor

All You Need in One Package

Image Processor

Although previous Vision Sensors placed the image processor in a separate Controller, now we have built the processor into the camera unit.

High-power Lighting

The Sensor includes high-power lighting capable of evenly lighting across a wide field of view. This provides sufficient lighting even when the enclosed polarizing filter is used.

Adjustable lens

The focus of the lens can be adjusted to take clear images for the specific field of view and installation distance you need.

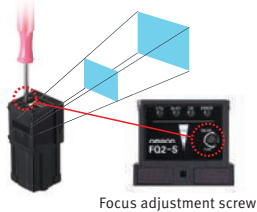

Focus adjustment screw

I/O Power Supply Connector

The external output line for inspection results, the input line for changing the setup, and the power supply line are all combined into one connector.

Ethernet Connector

Commands can be input from a PLC to control the FQ2, and inspection results and measurement results can be output from the FQ2 to a PLC.

You can also transfer images to a computer.



IP67 Water Resistance



The sensor still be used in wet environments.

Flexible Cables



All cables from the camera are flexible. This allows the Sensor to be used safely on moving parts.

Smart Click Connectors

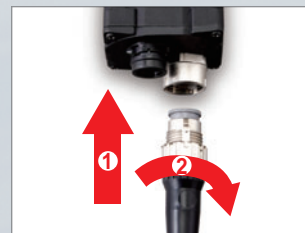

Connection is made quick and easy with a clear, definitive click-into-place mechanism.

Quick and Easy Design and Installation

Easy Product Selection

All you need to do is select the camera based on the field of view and installation distance that you require. There is no need to select and purchase additional lighting or lenses. Furthermore, the time required to wire everything has been drastically reduced due to the low number of components.

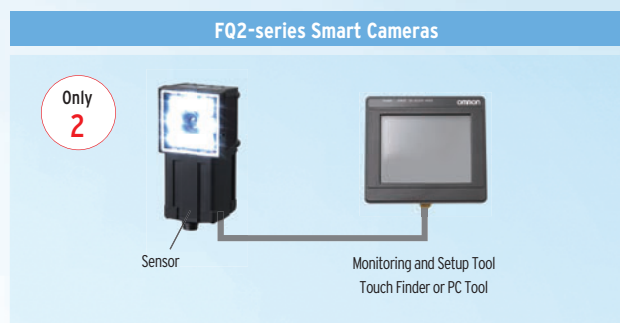
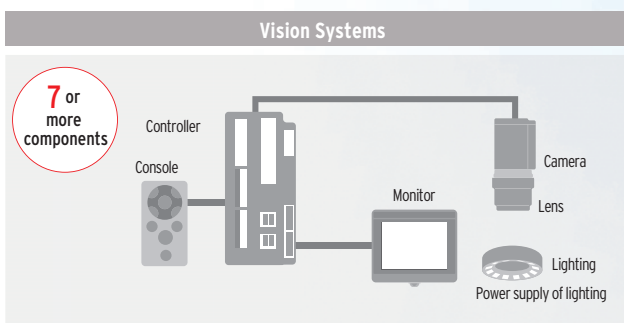

Easy Installation

The camera and lighting have been integrated into a single unit, so only one camera mounting bracket is required. The Sensor comes with a multi-directional mounting bracket that can be attached on any of the four sides of the Camera. Axis alignment is also not required because the lighting and the camera are integrated into a single unit.

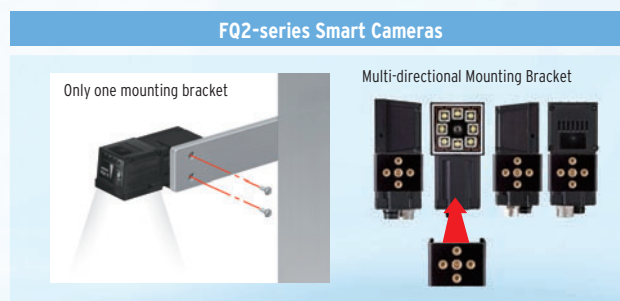
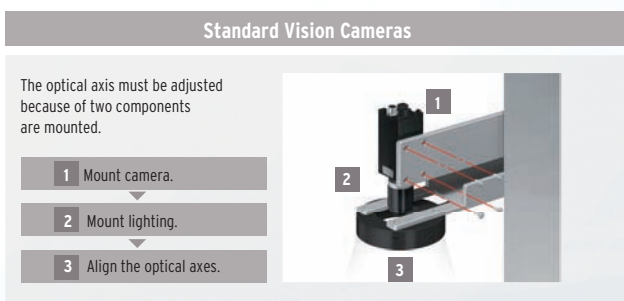

Easy Expansion Up to 32 Cameras

Just install the Cameras where you need them. No control panels are required to house the controllers. Triggers can be input for each Camera, so new Cameras can be added whenever required without having to worry about timing input design. Up to 32 Cameras can be set up from a single Touch Finder, so you also do not need to worry about adding new monitors when you need more Cameras. This also allows you to smoothly respond to user requests for additional features.

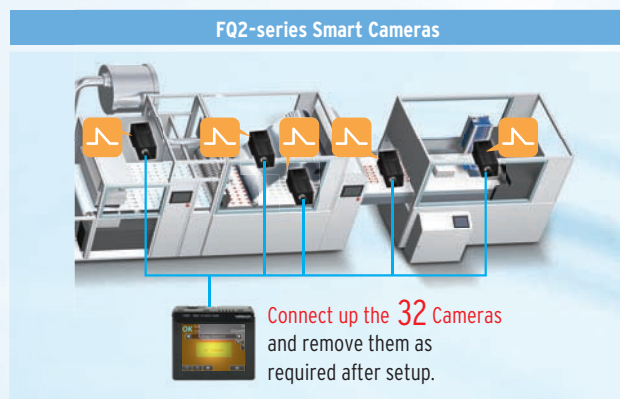
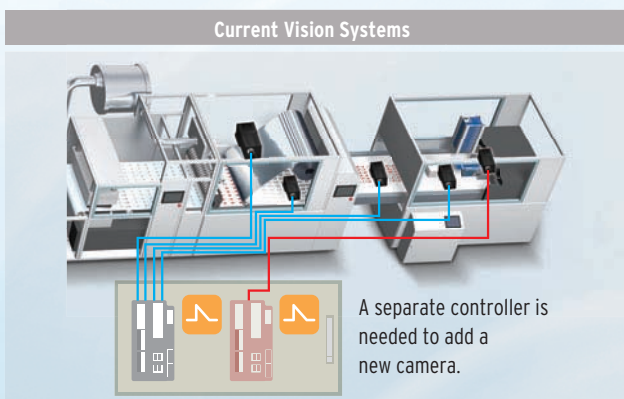

Extended Functions

Easily Perform Both Inspection and Positioning

You can combine multiple inspection items to perform external inspections, positioning, and other tasks all from a single Sensor.

External Inspection

External inspection of ICs can be completed with a single Sensor. The position offset of the entire pallet before inspection can be adjusted on the image itself, which reduces the amount of work required to increase mechanical positioning accuracy.

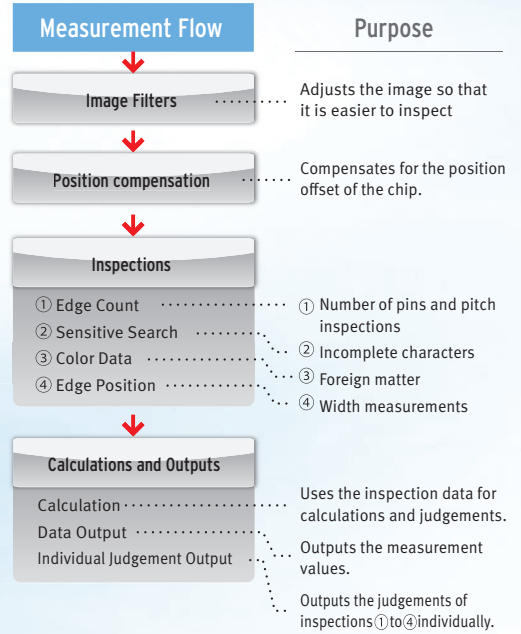
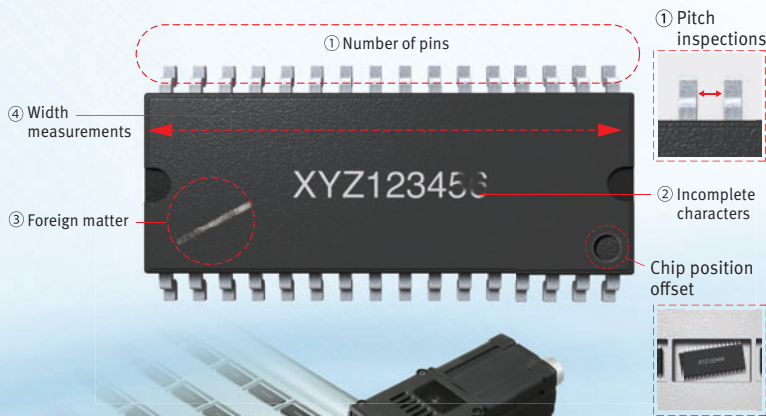

Component Positioning

The Sensor can measure angles of rotation and other position information, so it can also be used for positioning. Inspections can also be performed for the number and size of holes along with the position information.

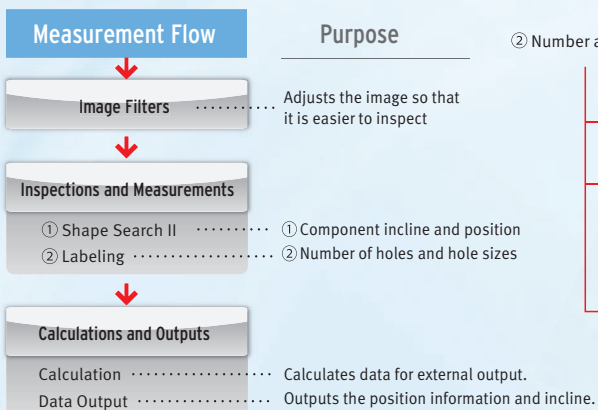

② Number and Sizes of Holes

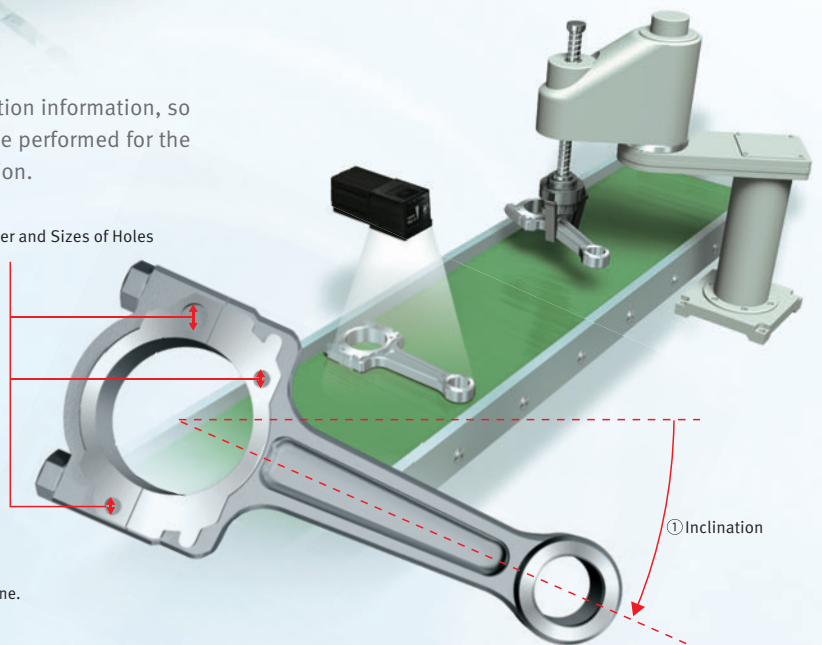

Incorporating the Best-selling Inspection Items from High-end Vision Systems

Searching

Shape Search II Ten Times Faster Than Previous Searching

General searches have a difficult time with overlap or 360° rotation, but this Sensor achieves high-speed, stable searching of any shapes that match the model.



Multiple searches can be performed simultaneously, which enables the inspection of the number of items in a pallet or picking applications.

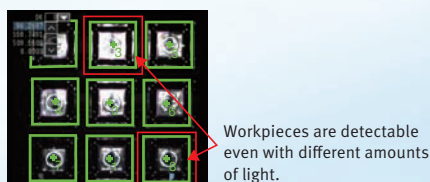

Sensitive Search

Through automatic division and matching of the model image, tiny differences that cannot be detected with a normal search can be detected with large numerical differences.

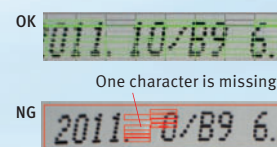

Searching

Search

This is a standard search inspection item. This type of search is used to detect items like labels, identify shapes, or positions.



Detection of Promotional Stickers

Edge Measurements

Edge Pitch

The number of edges in a region can be counted.

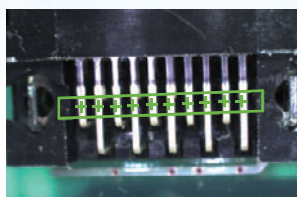

Edge Position

This inspection item detects edges and measures their positions.

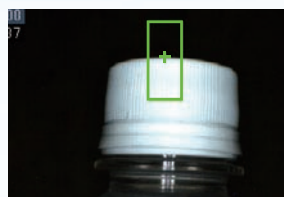

Edge Width

This inspection item measures the width between edges.



Area Measurements, Color Measurements, and Defect & Foreign Matter Detection

Labeling

This inspection item counts how many labels there are of the specified color and size and measures the area or center position of the specified label.



Area

This inspection item measures the area and center position of the specified color.



Color Data

Inspections can be performed that compare the difference in color between the workpiece and a registered image of a good product to detect objects and foreign matter. (average color value)

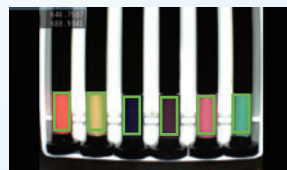

You can also inspect for defects and foreign matter by looking at the color deviation. (color deviation)



Utility Items

360° Rotational Position Compensation

The correct position of workpieces with an inconsistent orientation can be measured through automatic detection of the offset of the workpiece in relation to a registered standard model.

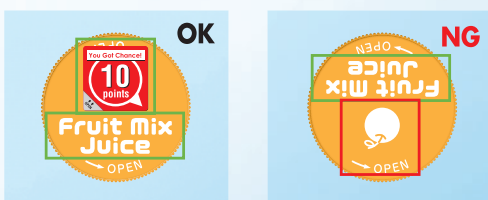
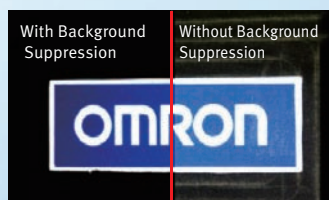

Image Filters

A total of 11 different image filters are provided, including background suppression to help eliminate patterns that can result in unstable measurements, as well as dilation and erosion.



Calibration

If the dimensions or position of a workpiece is difficult to determine in a pixel display, you can convert the display unit so that it is easier to see.

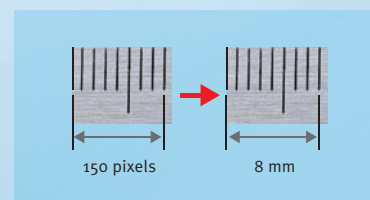

Versatile

A Lineup That Fits a Wide Range of Equipment

Sensor

We offer a diverse lineup of Sensors so that you can choose the one with the perfect field of view and installation distance for your needs.

Integrated Sensor

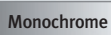

Note: Monochrome is FQ2-S3 Series only.

Seamless Field of View Variations

All-in-one Sensors tend to be limited in field of view variations, but we offer a lineup ranging from 7.5 mm up to 240 mm to meet your needs.

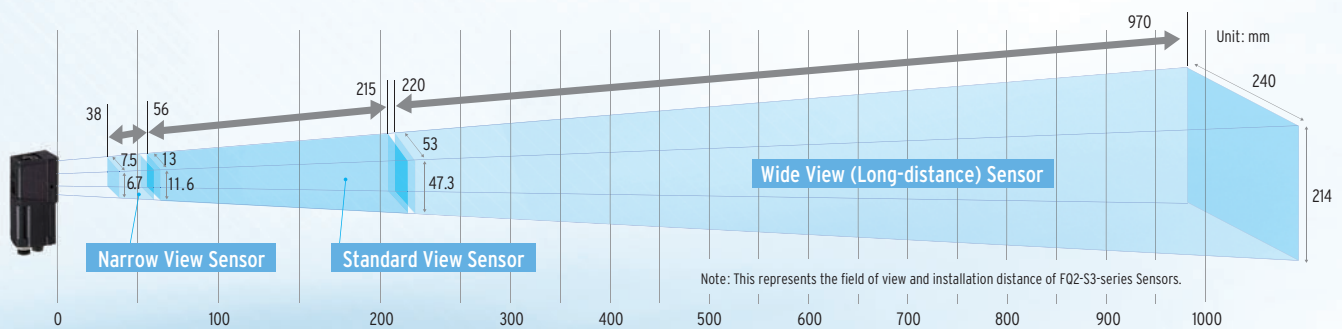

Wide View Sensors -- Perfect for Tight Spaces

A side-view wide-angle camera takes images and performs inspections across a wide area, even if the camera is close to the workpiece. This makes this type of Sensor perfect for when you need to mount the camera in locations with limited space. This also enables the Sensor to be installed alongside an assembly line without protruding in order to perform inspections from the side of the conveyor belt.

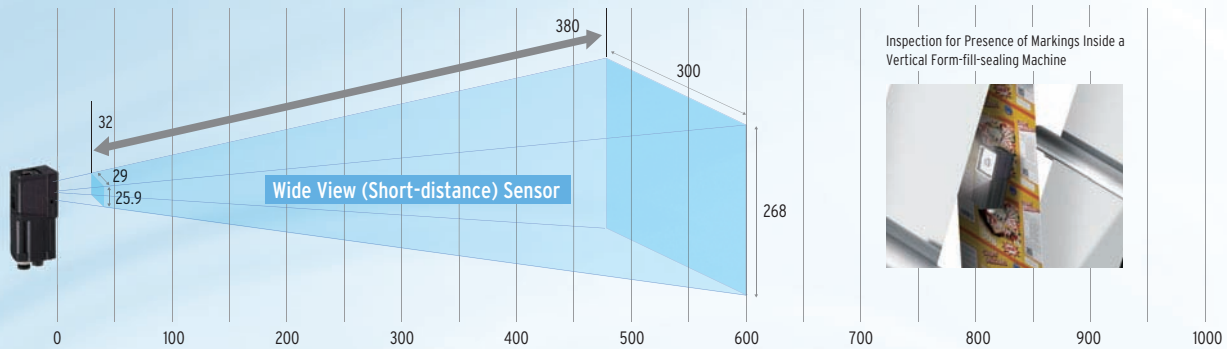

Sensors with C-mount lens

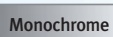

The Sensors with C-mount lens enable freedom of lens selection for long distances over 1 m and narrow fields of view under 1 mm that are not covered by our integrated Sensors. This type of Sensor is also useful when you want to use external illumination.

Long Distance



Narrow Field of View

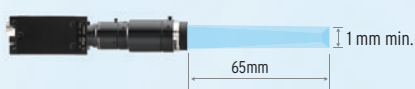

Note: A commercially available telecentric lens is required for narrow field of view applications.

Lighting Examples

Backlighting

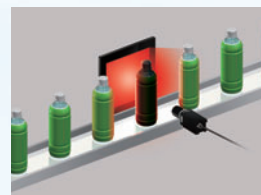

External Shape Inspections

Low-angle Lighting

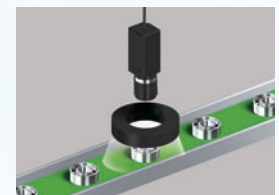

Defect and Foreign Matter Inspections

Communication Interfaces

The Sensor includes communication interfaces for compatibility with a wide range of host devices. This helps reduce the design work required for data communications between the Sensor and a PLC.



PLC Link

PLC link greatly reduces the amount of time and work that is required to create ladder programs.

FINS

OMRON's exclusive FINS/TCP communications interface can be used to connect to low-cost OMRON PLCs. With this communications interface, no communications controls are required to process the sending and receiving of complex TCP packets. You get faster, simpler connections to OMRON PLCs.

EtherNet/IP

EtherNet/IP communications, a standard widely used in communications systems in factories around the world, is also supported. This communication interface enables simple and easy connections to a wide range of EtherNet/IP devices, including OMRON PLCs.

I/O Expansion Units

Our expansion units enable expansion to up to three times the number of I/O connections. This enables the output of individual judgement results for each inspection, a feature that has been highly requested.

RS-232C Communications Unit

This Sensor Data Unit supports standard RS-232C communications.

Compatible Models

OMRON PLCs: CS, CJ, and NSJ Series
Mitsubishi Electric: Q Series

Compatible Models

OMRON PLCs: CP1L Series
OMRON PLCs: CJ Series

Compatible Models

OMRON
NJ-series Machine Programmable Controllers

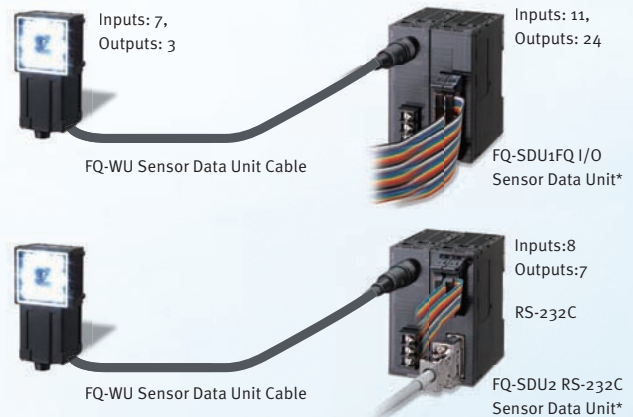

*.The Sensor Data Units can be connected only to the FQ2-S3 Series.

Setup Tools

We provide two tools for configuration and monitoring of inspection images: the Touch Finder, which can be used onsite to change settings and which can be installed on a control panel, and the PC Setup Tool which can be used from a computer.

Touch Finder

This is a small monitor with a touch panel. It's durable, rugged design is shock-resistant and portable. It has passed our standard 1.3 m drop test.

PC Tool

The Setup Tool provides the same functions as those on the Touch Finder, but on a PC. The software can be downloaded for free by any customer with the purchase of a Sensor. Refer to the member registration sheet that is enclosed with the sensor for details.

On-screen Messages in Nine Languages

- English
- Traditional Chinese
- Simplified Chinese
- Korean
- Japanese
- German
- French
- Italian
- Spanish

Hardware Advancements

High-speed Image Processor

3X Faster than Previous Models

20 Inspection Items per Second Processing Time

With our new high-speed image processor we are able to achieve a processing time of 50 ms or less for all primary inspection items.

* Processing may take longer than 50 ms depending on the settings.

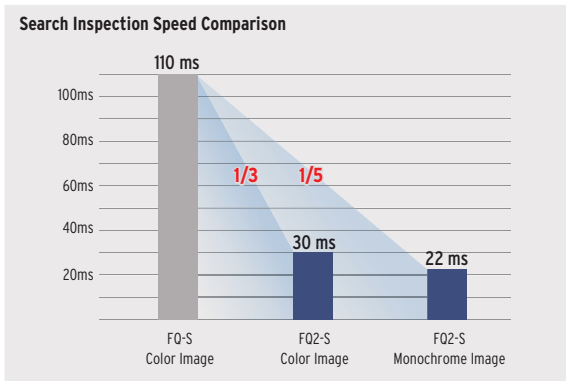

Note: This comparison was conducted with a 752 x 480 pixel image, with no rotational compensation.

Partial Input with DAP (Dual Axis Partial) Processing

Processing time can be further reduced by limiting the camera input to only the area that is required for inspection. Previous models allowed trimming only in the Y direction, but now you can specify a range across both the X and Y axes for trimming. Keep a wide field of view and trim to only the sections that are required for inspection in each scene to reduce processing time.

[Problems with a Standard Digital Zoom]
 Camera input is performed for all images and only a portion is shown enlarged, so this does not decrease the amount of time required for camera input.

Note: DAP processing is available only on FQ2-S3-series Sensors.

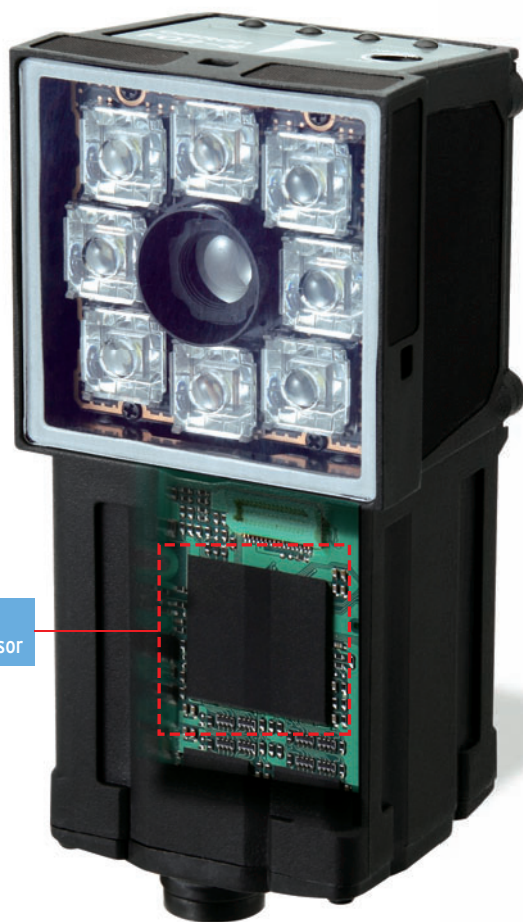

High-speed Image Processor

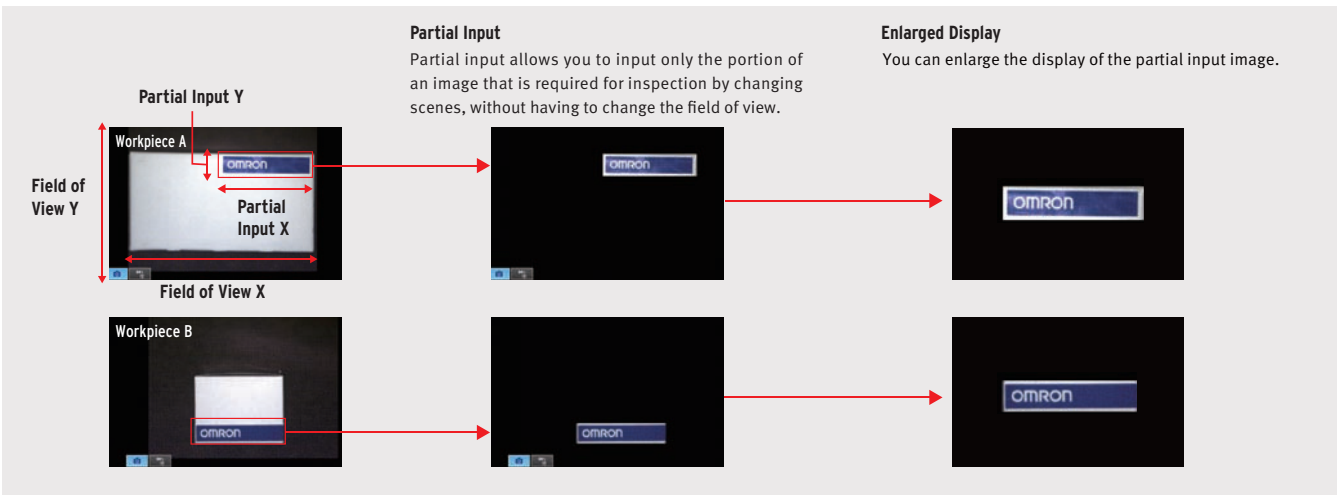

Megapixel CMOS Sensor

4 Times the Pixels × **1,000 Times the Display Resolution**

(Comparisons to previous OMRON models)

Precision 1.3 Megapixel Camera

Would you like a little more positioning accuracy?
 Do you need a wider field of view?
 We hear you, and that is why we have greatly improved the resolution of our camera.
 The 1.3 megapixels maintain precision and accuracy while also enabling a wider field of view.



350,000 pixels



1.3 megapixels

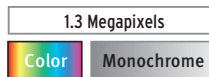

Sensor with C-mount

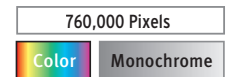

Integrated Sensor

*The number of pixels of F02-S1/S2 is 350,000.

Sub-pixel Processing

Previously, position information could only be output on a per-pixel basis, but now you can output at a resolution even higher than the number of available pixels. This provides finer measurement values for travel distances and helps to improve positioning accuracy.

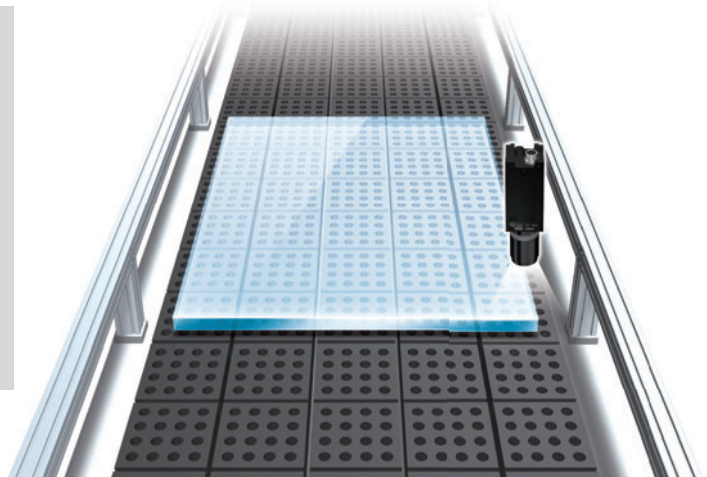
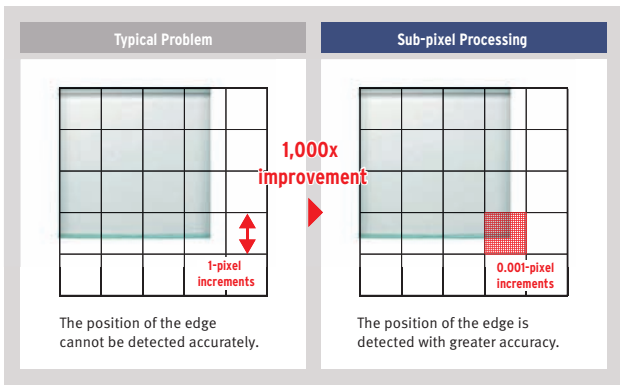

Three Key Technologies for Crystal Clear Images

Real-color Sensing

Real-color processing is an image processing technology that performs high-speed processing of full-color images with a total of 16.7 million colors (256 tones per RGB channel). This means that image processing can be performed with the same color information that is visible to the human eye, and stable measurements can be performed under lighting that closely resembles natural light.

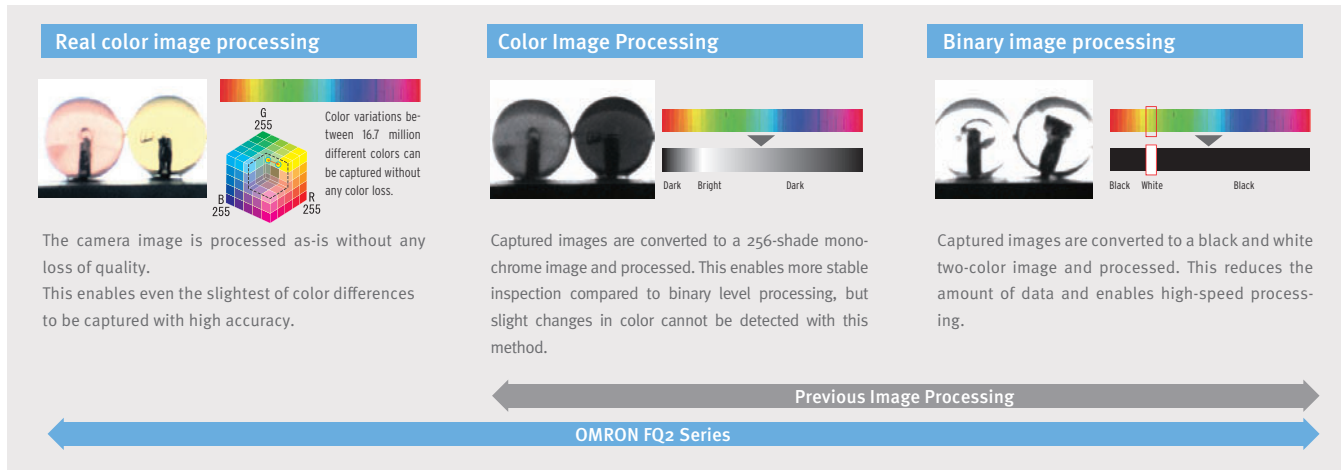

HDR Sensing

High dynamic range minimizes the effects of lighting such as halation and allows highly precise inspections.

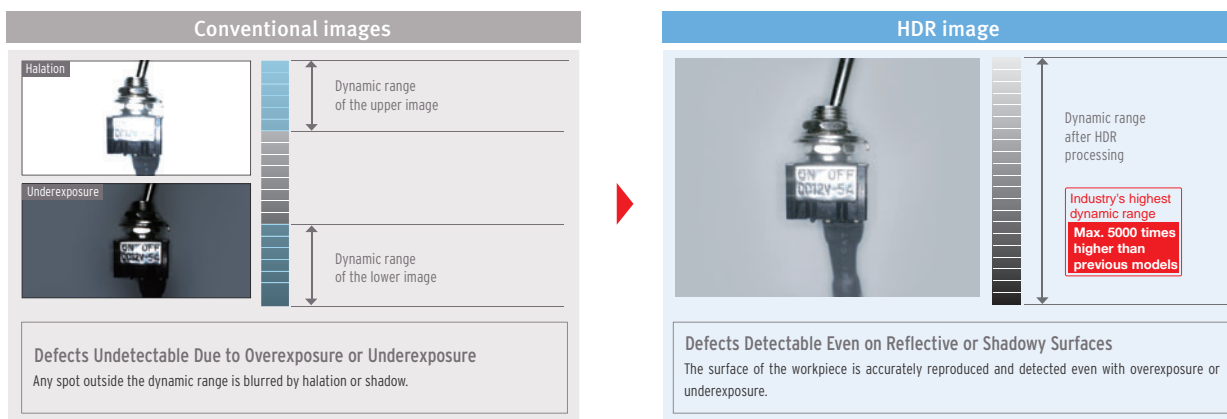

Polarizing Filter + High-power Lighting

Lighting is required for stable image inspection, but shiny surfaces can reflect light, resulting in incorrect judgements. You can use a polarizing filter to reduce specular reflection, but the entire image will be darker, which can result in insufficient image contrast. The FQ2 Series is equipped with OMRON's own high-power lighting DR optical system for effective use of LED power. This system provides sufficient lighting for inspection even when the enclosed polarizing filter is used.

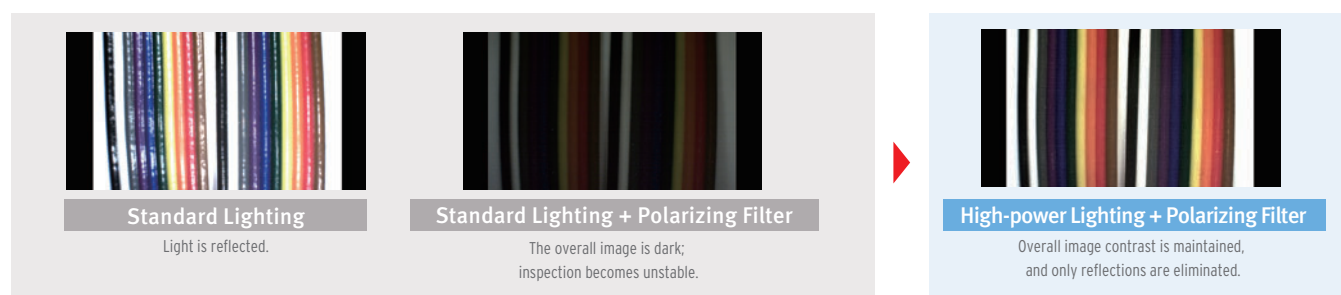

Useful Onsite Utilities

Real-time Threshold Adjustment

The FQ2 smart camera allows fast and easy real-time parameter adjustment. Eliminating the need to stop the machine for fine tuning and optimisation of settings, resulting in zero machine downtime.



Judgement conditions can be adjusted on the Touch Finder.

180° Inverted Image Display

Invert images by 180° when an image can only be taken in the incorrect orientation due to the position that the Sensor was mounted in.



Inspection History Logging

Historical results logging is very useful for testing a new line. Samples are fed down the line and inspection results are logged. The logged data can be checked on a time scale in graph form and used to adjust judgement conditions. File Logging is convenient during operation. Large inspection history can be saved on SD cards and used later for traceability.

Recent Results Logging



Displays the most recent 1,000 inspection results in graph form.

File Logging

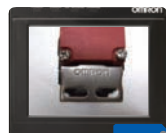

SD card
 Up to 10 million measurement values or more (for a 4-GB SD card)
 Up to 10,000 images or more (for a 4-GB SD card)

Password Protection

A password can be set to prevent changes to settings during operation by restricting the ability to change from Run Mode to Setup Mode.

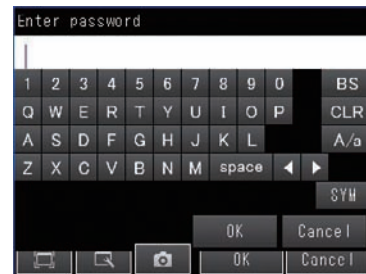

Auto Detection

When multiple sensors are connected to the touch finder, the display automatically switches to the image of the sensor which has produced an NG result. This allows dynamic visualization of reject conditions.

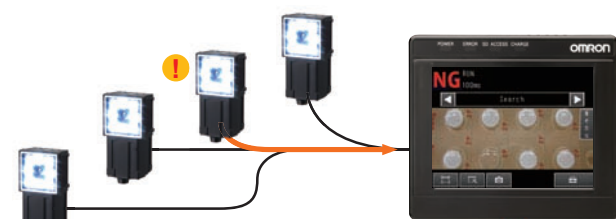

Automatically NG sensor image is displayed !

Note. When 32 sensors are connected, the most recent NG sensor of 8 sensors selected for display is displayed.

Shortcuts

Shortcuts to Setup Menu items that are changed frequently can be added to the Run Mode display.

This enables the user to quickly perform adjustments when a problem occurs during operation.

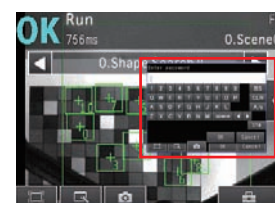

Directly access frequently used functions.

System Configuration

Ethernet (EtherNet/IP, No-protocol, or PLC Link) Connection

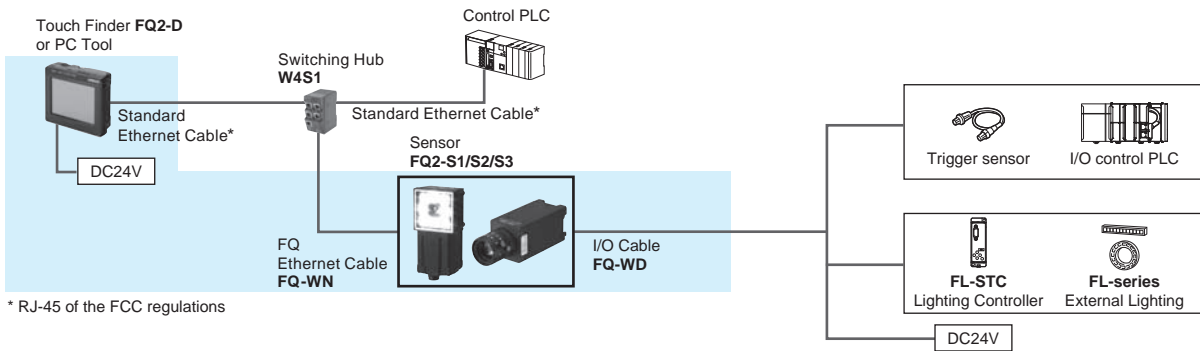

* RJ-45 of the FCC regulations

Parallel Interface Connection

Connection with Standard Parallel Interface of the Vision Sensor

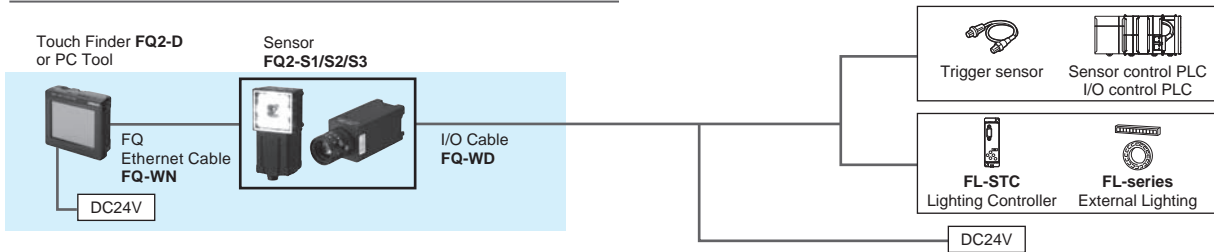

Connection through a Parallel Interface Sensor Data Unit (FQ2-S3 only)

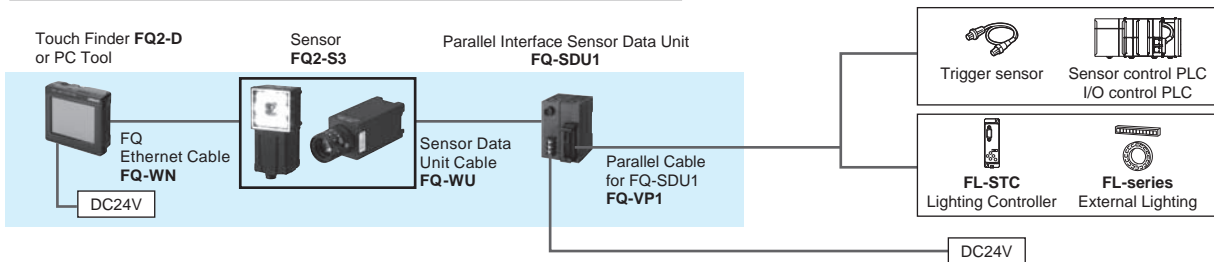

RS-232C Serial Connection (FQ2-S3 only)

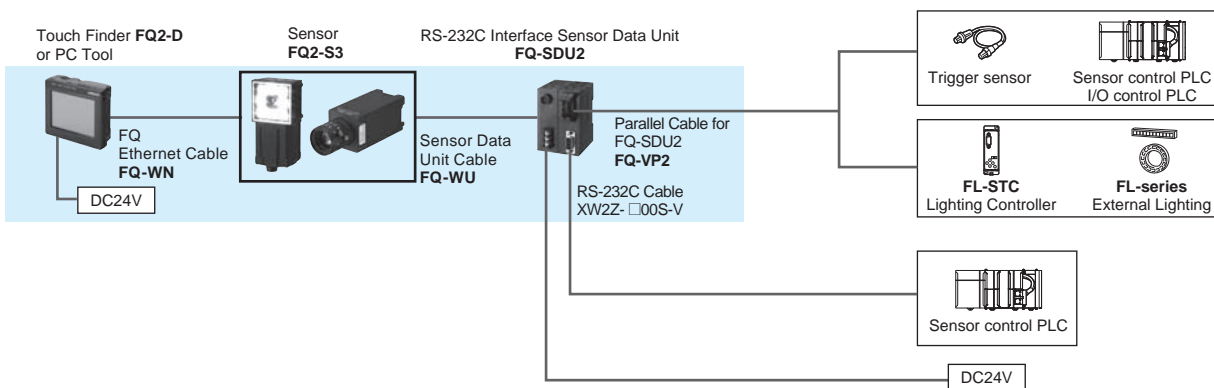

Connecting More Than One Sensor

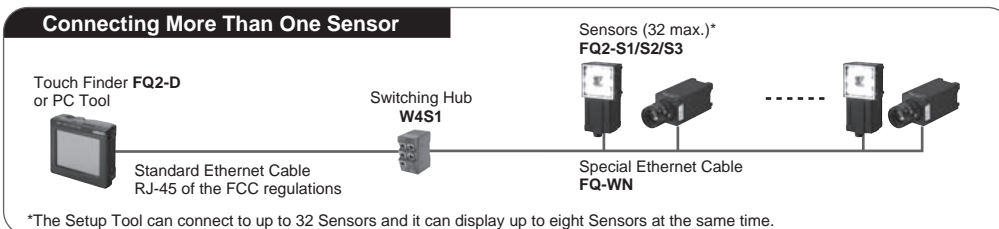





*The Setup Tool can connect to up to 32 Sensors and it can display up to eight Sensors at the same time.

Note: If you register as a member after purchasing a Sensor, you can download free setup software that runs on a PC and can be used in place of Touch Finder. Refer to the member registration sheet for details.

Sensor



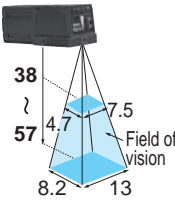
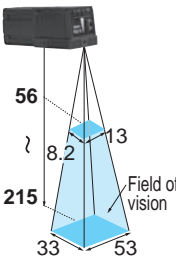
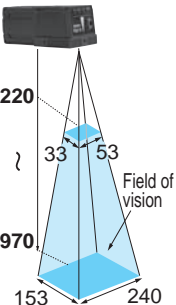
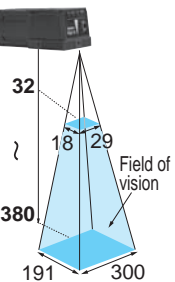

Single-Function Models FQ2-S1 Series

Field of vision	Narrow View	Standard View	Wide View (Long-distance)	Wide View (Short-distance)	
Appearance					
Number of pixels	350,000 pixels				
Color	NPN	FQ2-S10010F	FQ2-S10050F	FQ2-S10100F	FQ2-S10100N
	PNP	FQ2-S15010F	FQ2-S15050F	FQ2-S15100F	FQ2-S15100N
Field of vision/ Installation distance					

Standard Models FQ2-S2 Series

Field of vision	Narrow View	Standard View	Wide View (Long-distance)	Wide View (Short-distance)	
Number of pixels	350,000 pixels				
Color	NPN	FQ2-S20010F	FQ2-S20050F	FQ2-S20100F	FQ2-S20100N
	PNP	FQ2-S25010F	FQ2-S25050F	FQ2-S25100F	FQ2-S25100N
Field of vision/ Installation distance	Same as Single-Function Models FQ2-S1 series. Refer to the above figures.				

High-Resolution Models FQ2-S3 Series

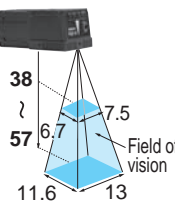
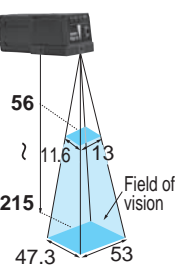
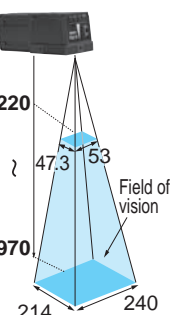
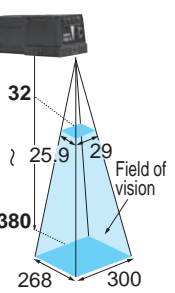
Field of vision	Narrow View	Standard View	Wide View (Long-distance)	Wide View (Short-distance)	C-mount	
Appearance						
Number of pixels	760,000 pixels				1.3 million pixels	
Color	NPN	FQ2-S30010F-08	FQ2-S30050F-08	FQ2-S30100F-08	FQ2-S30100N-08	FQ2-S30-13
	PNP	FQ2-S35010F-08	FQ2-S35050F-08	FQ2-S35100F-08	FQ2-S35100N-08	FQ2-S35-13
Monochrome	NPN	FQ2-S30010F-08M	FQ2-S30050F-08M	FQ2-S30100F-08M	FQ2-S30100N-08M	FQ2-S30-13M
	PNP	FQ2-S35010F-08M	FQ2-S35050F-08M	FQ2-S35100F-08M	FQ2-S35100N-08M	FQ2-S35-13M
Field of vision/ Installation distance					Refer to the optical chart on p.22.	

Sensor Data Unit (FQ2-S3 only)

Type	Appearance	Output type	Model
Parallel Interface		NPN	FQ-SDU10
		PNP	FQ-SDU15



Type	Appearance	Output type	Model
RS-232C Interface		NPN	FQ-SDU20
		PNP	FQ-SDU25

Note: Refer to the System Configuration to select cables required to use the Sensor Data Unit.

Touch Finder

Type	Appearance	Model
DC power supply		FQ2-D30
AC/DC/battery		FQ2-D31

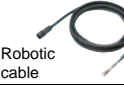
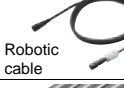
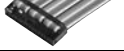
Cables



Type	Appearance	Cable length	Model
FQ Ethernet Cables (connect Sensor to Touch Finder, Sensor to PC)		2m	FQ-WN002
		5m	FQ-WN005
		10m	FQ-WN010
		20m	FQ-WN020
I/O Cables		2m	FQ-WD002
		5m	FQ-WD005
		10m	FQ-WD010
		20m	FQ-WD020
Sensor Data Unit Cable		2m	FQ-WU002
		5m	FQ-WU005
		10m	FQ-WU010
		20m	FQ-WU020
Parallel Cable for FQ-SDU1 (See note)		2m	FQ-VP1002
		5m	FQ-VP1005
		10m	FQ-VP1010
Parallel Cable for FQ-SDU2 (See note)		2m	FQ-VP2002
		5m	FQ-VP2005
		10m	FQ-VP2010
RS-232C Cable for FQ-SDU2		2m	XW2Z-200S-V
		5m	XW2Z-500S-V

Note: Use two FQ-VP Cables when using all signals.

External Lighting

Type	Model
3Z4S-LT Series	Refer to 3Z4S-LT/LE Series Catalog(Q164)
FL Series	Refer to FL Series Catalog(Q181)

Industrial Switching Hubs (Recommended)

Appearance	Number of ports	Failure detection	Current consumption	Model
	3	None	0.22 A	W4S1-03B
	5	None	0.22 A	W4S1-05B
		Supported		W4S1-05C

Lenses for C-mount Camera

Refer to the optical chart on p.22 for selection of a lens.









High-resolution, Low-distortion Lenses

Model	3Z4S-LE SV-0614H	3Z4S-LE SV-0814H	3Z4S-LE SV-1214H	3Z4S-LE SV-1614H	3Z4S-LE SV-2514H	3Z4S-LE SV-3514H	3Z4S-LE SV-5014H	FZ-LEH75	FZ-LEH100
Appearance									
Focal length	6mm	8mm	12mm	16mm	25mm	35mm	50mm	75mm	100mm
Brightness	F1.4	F1.4	F1.4	F1.4	F1.4	F1.4	F1.4	F2.5	F2.8
Filter size	M40.5 P0.5	M35.5 P0.5	M27 P0.5	M27 P0.5	M27 P0.5	M35.5 P0.5	M40.5 P0.5	M34.0 P0.5	M40.5 P0.5

Extension Tubes

Model	3Z4S-LE SV-EXR
Contents	Set of 7 tubes (40 mm, 20 mm, 10 mm, 5 mm, 2.0 mm, 1.0 mm, and 0.5 mm) Maximum outer diameter: 30 mm dia.

Accessories

Application	Appearance	Name	Model
For Sensor		Mounting Bracket (included with Sensor)	FQ-XL
		Mounting Bracket (sold separately)	FQ-XL2
		Mounting Base for C-mount type (included with Sensor)	FQ-XLC
		Polarizing Filter Attachment (included with Sensor)	FQ-XF1
For Touch Finder		Panel Mounting Adapter	FQ-XPM
		AC Adapter (for AC/DC/battery model)	FQ-A□ (See note)
		Battery (for AC/DC/battery model)	FQ-BAT1
		Touch Pen (enclosed with Touch Finder)	FQ-XT
		Strap	FQ-XH

Note: AC Adapters for Touch Finder with DC / AC / Battery Power Supply.
Select the model for the country in which the Touch Finder will be used.

Plug Type	Voltage	Certified standards	Model
A	125 V max.	PSE	FQ-AC1
	250 V max.	UL/CSA	FQ-AC2
C	250 V max.	CCC mark	FQ-AC3
BF	250 V max.	---	FQ-AC4
C	250 V max.	---	FQ-AC5
C	250 V max.	---	FQ-AC6

* Do not use the 0.5-mm, 1.0-mm, and 2.0-mm Extension Tubes attached to each other. Since these Extension Tubes are placed over the threaded section of the Lens or other Extension Tube, the connection may loosen when more than one 0.5-mm, 1.0- mm or 2.0-mm Extension Tube are used together.

* Reinforcement may be required for combinations of Extension Tubes exceeding 30 mm if the Camera is subject to vibration.

Sensor

Item		Single-function models	Standard models	High-resolution models				
Model	NPN	FQ2-S10□□□□	FQ2-S20□□□□	FQ2-S30□□□□-08	FQ2-S30□□□□-08M	FQ2-S30-13	FQ2-S30-13M	
	PNP	FQ2-S15□□□□	FQ2-S25□□□□	FQ2-S35□□□□-08	FQ2-S35□□□□-08M	FQ2-S35-13	FQ2-S35-13M	
Field of view		Refer to Ordering Information on p.15. (Tolerance (field of vision): ±10% max.)					Select a lens according to the field of vision and installation distance.	
Installation distance							Refer to the optical chart on p.22.	
Main functions	Inspection items	Search, shape search II, sensitive search, area, color data, edge position, edge pitch, edge width, and labeling						
	Number of simultaneous measurements	1	32					
	Position compensation	Supported (360° Model position compensation, Edge position compensation)						
	Number of registered scenes	8	32					
	Calibration	Supported						
Image input	Image processing method	Real color			Monochrome	Real color	Monochrome	
	Image filter	High dynamic range (HDR), image adjustment, polarizing filter (attachment), and white balance (Sensors with Color Cameras only)						
	Image elements	1/3-inch color CMOS		1/2-inch color CMOS	1/2-inch Monochrome CMOS	1/2-inch color CMOS	1/2-inch Monochrome CMOS	
	Shutter	Built-in lighting ON: 1/250 to 1/60,000 , Built-in lighting not OFF: 1/1 to 1/60,000					1/1 to 1/60,000	
	Processing resolution	752 × 480		928 × 828		1280 × 1024		
	Partial input function	Supported horizontally only.		Supported horizontally and vertically				
	Lens mounts	---					C-mount	
Lighting	Lighting method	Pulse				---		
	Lighting color	White				---		
Data logging	Measurement data	In Sensor: 1,000 items (If a Touch Finder is used, results can be saved up to the capacity of an SD card.)						
	Images	In Sensor: 20 images (If a Touch Finder is used, images can be saved up to the capacity of an SD card.)						
Auxiliary function		Math (arithmetic, calculation functions, trigonometric functions, and logic functions)						
Measurement trigger		External trigger (single or continuous) Communications trigger (Ethernet TCP no-protocol, Ethernet FINS/TCP no-protocol, EtherNet/IP, or PLC Link)						
I/O specifications	Input signals	7 signals • Single measurement input (TRIG) • Control command input (IN0 to IN5)						
	Output signals	3 signals • Control output (BUSY) • Overall judgement output (OR) • Error output (ERROR) Note: The assignments of the three output signals (OUT0 to OUT2) can be changed to the individual judgements of the inspection items, the image input ready output (READY), or the external lighting timing output (STGOUT).						
	Ethernet specifications	100Base-TX/10Base-T						
	Communications	Ethernet TCP no-protocol, Ethernet FINS/TCP no-protocol, EtherNet/IP, or PLC Link						
	I/O expansion	---	---	Possible by connecting FQ-SDU1_ Sensor Data Unit. 11 inputs and 24 outputs				
	RS-232C	---	---	Possible by connecting FQ-SDU2_ Sensor Data Unit.				
Ratings	Power supply voltage	21.6 to 26.4 VDC (including ripple)						
	Current consumption	2.4 A max.				0.3 A max.		
Environmental immunity	Ambient temperature range	Operating: 0 to 50°C Storage: -25 to 65°C (with no icing or condensation)						
	Ambient humidity range	Operating and storage: 35% to 85% (with no condensation)						
	Ambient atmosphere	No corrosive gas						
	Vibration resistance (destruction)	10 to 150 Hz, single amplitude: 0.35 mm, X/Y/Z directions 8 min each, 10 times						
	Shock resistance (destruction)	150 m/s ² 3 times each in 6 direction (up, down, right, left, forward, and backward)						
	Degree of protection	IEC 60529 IP67 (Except when Polarizing Filter Attachment is mounted or connector cap is removed.)				IEC 60529 IP40		
Materials		Sensor: PBT, PC, SUS Mounting Bracket: PBT Polarizing Filter Attachment: PBT, PC Ethernet connector: Oil-resistance vinyl compound I/O connector: Lead-free heat-resistant PVC				Cover: Zinc-plated steel, Thickness: 0.6 mm Case: Aluminum diecast alloy (ADC-12) Mounting base: Polycarbonate ABS		
Weight		Narrow View/Standard View: Approx.160 g Wide View: Approx.150 g				Approx. 160 g without base, Approx. 185 g with base		
Accessories		Mounting Bracket (FQ-XL)(1) Polarizing Filter Attachment (FQ-XF1) (1) Instruction Manual , Quick Startup Guide Member Registration Sheet , Warning Label				Mounting Base (1) Mounting Screw (M3 × 8mm)(4) Instruction Manual , Quick Startup Guide Member Registration Sheet		
LED class*2		Class 2(Applicable standards: IEC 60825-1:1993 +A1:1997 +A2:2001, EN 60825-1:1994 +A1:2002 +A2:2001, and JIS C 6802:2005)				---		
Applicable standards		EN standard EN 61326 and EC Directive No.2004/104/EC		EN 61326-1:2006 and IEC 61010-1				

Touch Finder

Item	Model	Type	Model with DC power supply	Model with AC/DC/battery power supply
			FQ2-D30	FQ2-D31
Number of connectable Sensor			Number of sensors that can be recognized (switched): 32 max. number or sensor that can displayed on monitor: 8 max.	
Main functions	Types of measurement displays		Last result display, Last NG display, trend monitor, histograms	
	Types of display images		Through, frozen, zoom-in, and zoom-out images	
	Data logging		Measurement results, measured images	
	Menu language		English, German, French, Italian, Spanish, Traditional Chinese, Simplified Chinese, Korean, Japanese	
Indications	LCD	Display device	3.5-inch TFT color LCD	
		Pixels	320 × 240	
		Display colors	16.7 million	
	Backlight	Life expectancy (See note 1.)	50,000 hours at 25°C	
		Brightness adjustment	Provided	
		Screen saver	Provided	
Operation interface	Touch screen	Method	Resistance film	
		Life expectancy (See note 2.)	1,000,000 touch operations	
External interface	Ethernet		100BASE-TX/10BASE-T	
	SD card		SDHC-compliant, Class 4 or higher recommended	
Ratings	Power supply voltage		DC power connection: 21.6 to 26.4 VDC (including ripple)	DC power connection: 21.6 to 26.4 VDC (including ripple) AC adapter (manufactured by Sino-American Japan Co., Ltd) connection: 100 to 240 VAC, 50/60 Hz Battery connection: FQ-BAT1 Battery (1cell, 3.7 V)
	Continuous operation on Battery (See note 3.)		---	1.5 h
	Power consumption		DC power connection: 0.2 A max.	DC power connection: 0.2 A max. Charging battery: 0.4 A max.
Environmental immunity	Ambient temperature range		Operating: 0 to 50°C Storage: -25 to 65°C (with no icing or condensation)	Operating: 0 to 50°C when mounted to DIN Track or panel Operation on Battery: 0 to 40°C Storage: -25 to 65°C (with no icing or condensation)
	Ambient humidity range		Operating and storage: 35% to 85% (with no condensation)	
	Ambient atmosphere		No corrosive gas	
	Vibration resistance (destruction)		10 to 150 Hz, single amplitude: 0.35 mm, X/Y/Z directions 8 min each, 10 times	
	Shock resistance (destruction)		150 m/s ² 3 times each in 6 direction (up, down, right, left, forward, and backward)	
Degree of protection		IEC 60529 IP20 (when SD card cover, connector cap, or harness is attached)		
Weight		Approx. 270 g (without Battery and hand strap attached)		
Materials		Case: ABS		
Accessories		Touch Pen (FQ-XT), Instruction Manual		

- Note:**
- This is a guideline for the time required for the brightness to diminish to half the initial brightness at room temperature and humidity. The life of the backlight is greatly affected by the ambient temperature and humidity and will be shorter at lower or higher temperatures.
 - This value is only a guideline. No guarantee is implied. The value will be affected by operating conditions.
 - This value is only a guideline. No guarantee is implied. The value will be affected by the operating environment and operating conditions.

Sensor Data Units(FQ2-S3 only)

Item	Parallel Interface		RS-232C Interface
Model	NPN	FQ-SDU10	FQ-SDU20
	PNP	FQ-SDU15	FQ-SDU25
I/O specifications	Parallel I/O	Connector 1	6 inputs(IN0 to IN5)
		Connector 2	2 inputs(TRIG and RESET) 7 outputs(ACK, RUN, BUSY, OR, ERROR, STGOUT, and SHTOUT)
	RS-232C		1 channel, 115,200 bps max.
	Sensor interface		FQ2-S3 connected with FQ-WU□□□ : OMRON interface *Number of connected Sensors: 1
Ratings	Power supply voltage		21.6 to 26.4 VDC (including ripple)
	Insulation resistance		Between all DC external terminals and case: 0.5 MΩ min (at 250 VDC)
	Current consumption		System: 2.5 A max.
Environmental immunity	Ambient temperature range		Operating: 0 to 50°C, Storage: -20 to 65°C (with no icing or condensation)
	Ambient humidity range		Operating and storage: 35% to 85% (with no condensation)
	Ambient atmosphere		No corrosive gas
	Vibration resistance (destruction)		10 to 150 Hz, single amplitude: 0.35 mm, X/Y/Z directions, 8 min each, 10 times
	Shock resistance (destruction)		150 m/s ² 3 times each in 6 directions (up, down, right, left, forward, and backward)
Degree of protection		IEC 60529 IP20	
Materials		Case: PC + ABS, PC	
Weight		Approx. 150 g	
Accessories		Instruction Manual	

Battery

Item	Model	FQ-BAT1
Battery type		Secondary lithium ion battery
Nominal capacity		1,800 mAh
Rated voltage		3.7 V
Ambient temperature range		Operating: 0 to 40°C Storage: -25 to 65°C (with no icing or condensation)
Ambient humidity range		Operating and storage: 35% to 85% (with no condensation)
Charging method		Charged in Touch Finder (FQ2-D31). AC adapter (FQ-AC□) is required.
Charging time (See note 1.)		2 h
Usage time (See note 1.)		1.5 h
Battery backup life (See note 2.)		300 charging cycles
Weight		50 g max.

Note: 1. This value is only a guideline. No guarantee is implied. The value will be affected by operating conditions

2. This is a guideline for the time required for the capacity of the Battery to be reduced to 60% of the initial capacity. No guarantee is implied. The value will be affected by the operating environment and operating conditions.

System Requirements for PC tool for FQ

The following Personal Computer system is required to use the software.

OS	Microsoft Windows XP Home Edition/Professional SP2 or higher (32-bit/64-bit version) Microsoft Windows 7 Home Premium or higher (32-bit/64-bit version)
CPU	Core 2 Duo 1.06 GHz or the equivalent or higher
RAM	1GB min.
HDD	500 MB min. available space (See note)
Monitor	1,024 × 768 dots min.

Note: Available space is also required separately for data logging.

Windows is registered trademarks of Microsoft Corporation in the USA and other countries.
Other company names and product names in this document are the trademarks or registered trademarks of their respective companies.

Sensor

Integrated Sensor

Narrow View

- FQ2-S10010F/S15010F
- FQ2-S20010F/-S25010F
- FQ2-S30010F-08/-S35010F-08/-S30010F-08M/-S35010F-08M

Standard View

- FQ2-S10050F/-S15050F
- FQ2-S20050F/-S25050F
- FQ2-S30050F-08/S35050F-08/-S30050F-08M/-S35050F-08M

Wide View(Long-distance)

- FQ2-S10100F/-S15100F
- FQ2-S20100F/-S25100F
- FQ2-S30100F-08/-S35100F-08/-S30100F-08M/-S35100F-08M

Wide View(Short-distance)

- FQ2-S10100N/-S15100N
- FQ2-S20100N/-S25100N
- FQ2-S30100N-08/-S35100N-08/-S30100N-08M/-S35100N-08M

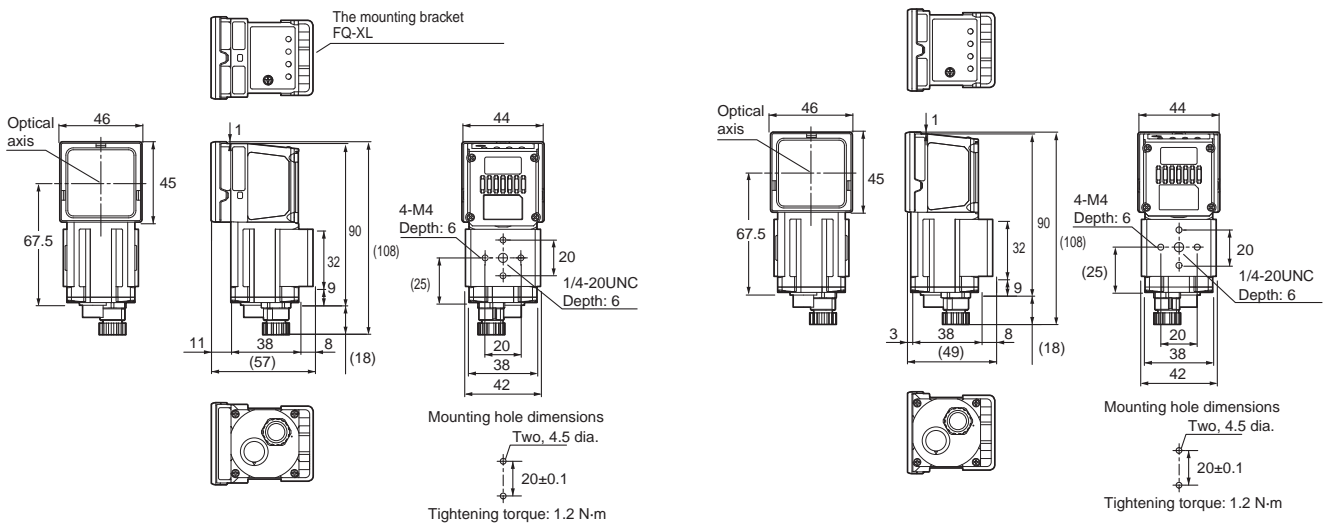

C-mount

FQ2-S30-13/-S35-13/-S30-13M/-S35-13M

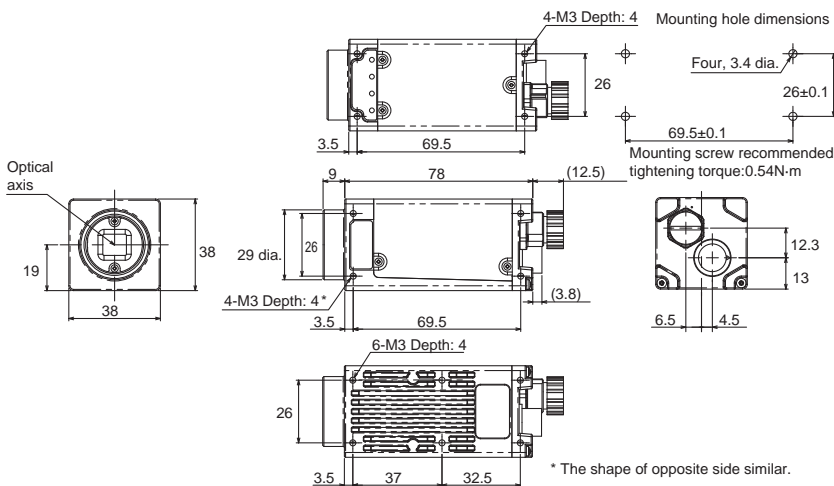

Mounting Base FQ-XLC (included with Sensor)

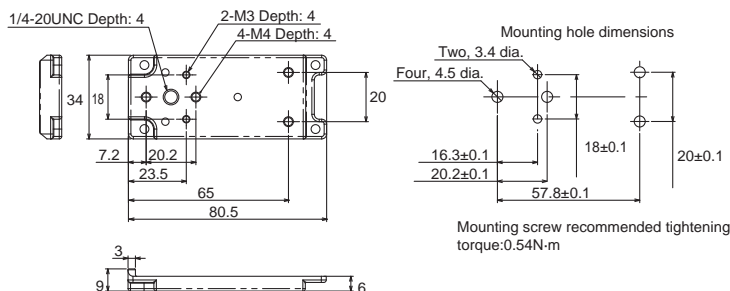

Touch Finder

FQ2-D30/-D31

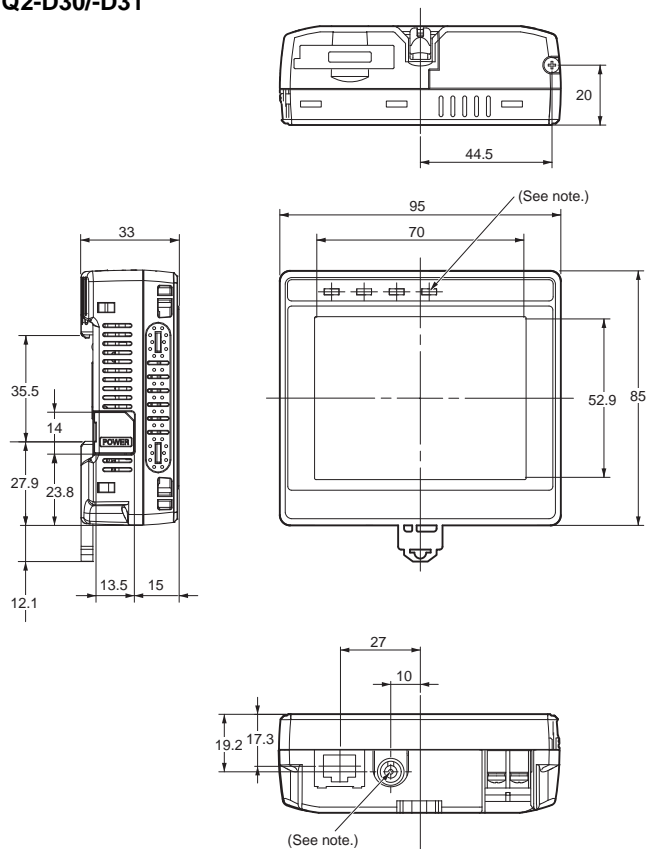

Panel Mounting Adapter FQ-XPM

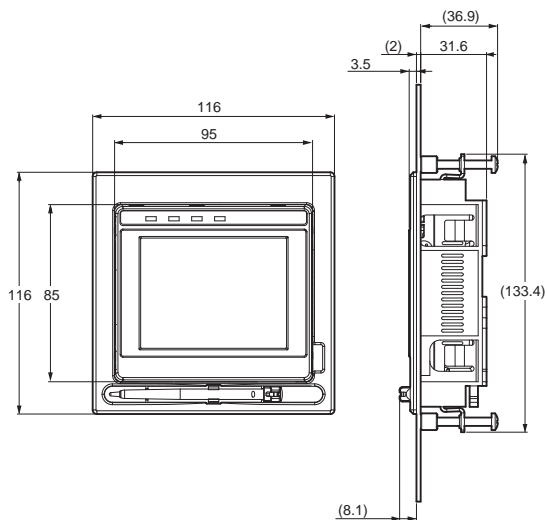

Panel Cutout Dimensions

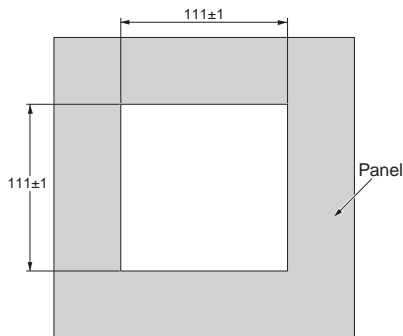

Note: Provided with FQ-D31 only.

Sensor Data Unit

FQ-SDU10/-SDU15

FQ-SDU20/-SDU25

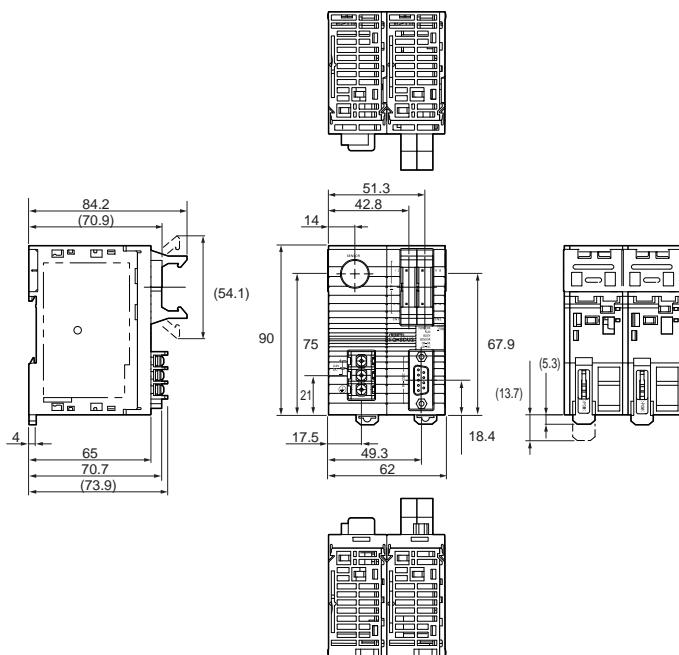
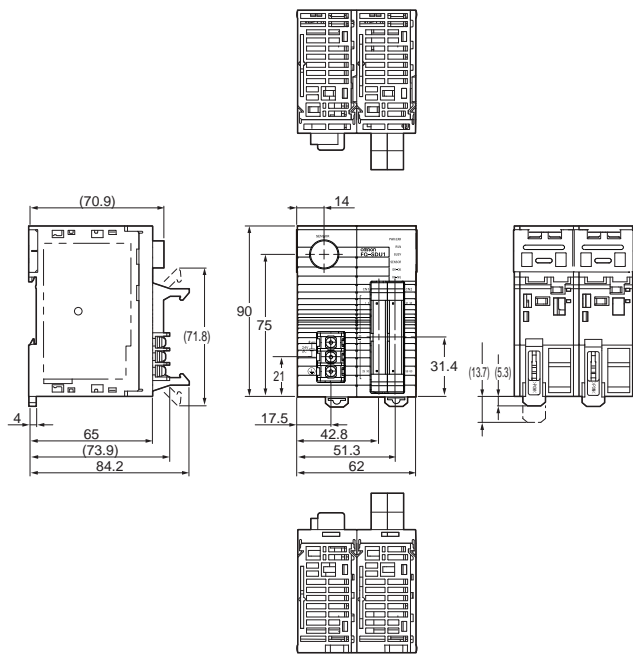

High-resolution, Low-distortion Lenses 3Z4S-LE SV-□□□□H/FZ-LEH Series

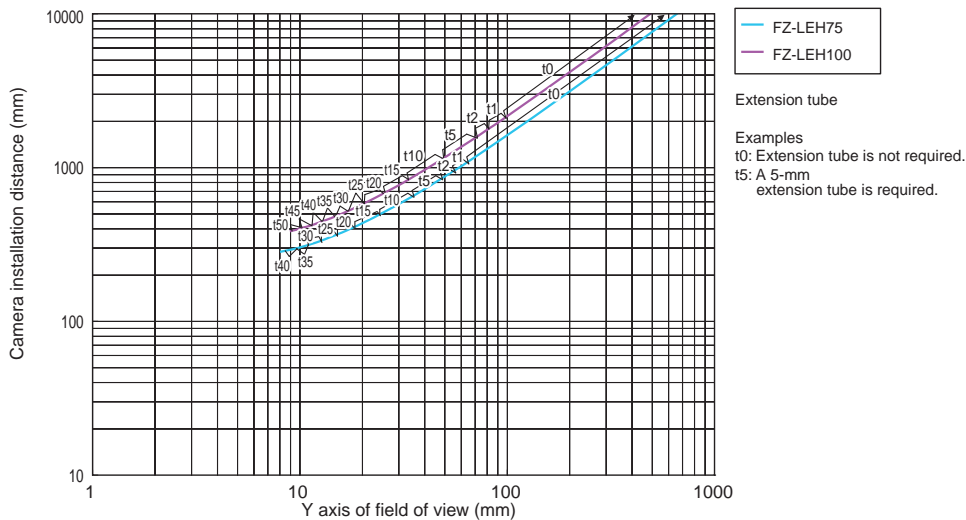
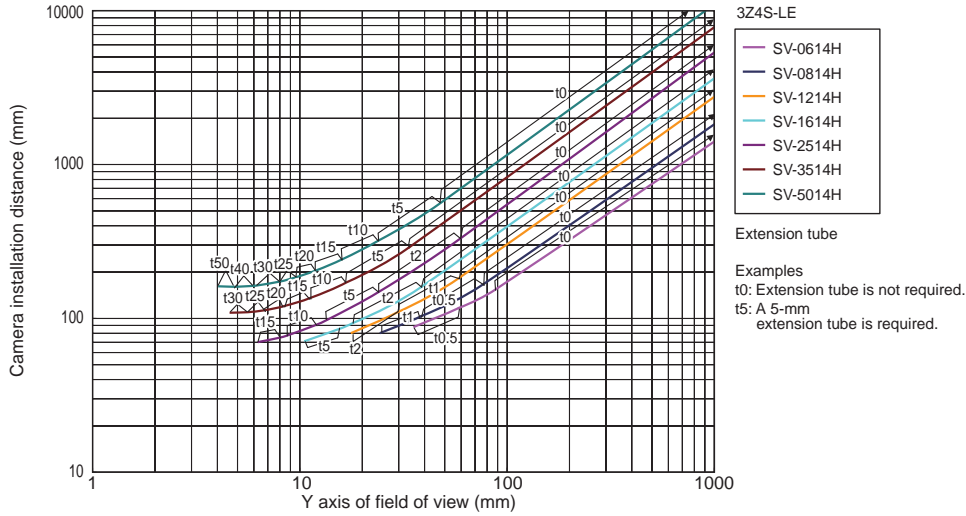

Meaning of Optical Chart

The X axis of the optical chart shows the field of vision (mm) (See Note.), and the Y axis of the optical chart shows the camera installation distance (mm).

Note: The lengths of the fields of vision given in the optical charts are the lengths of the Y axis.

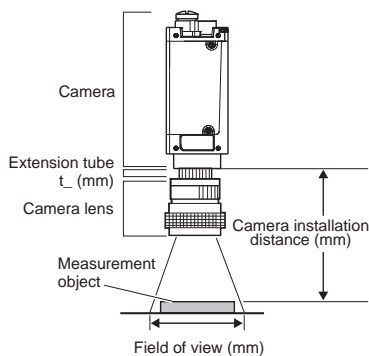

Related Manuals

Man.No.	Model number	Manual
Z326	FQ2	User's Manual

READ AND UNDERSTAND THIS CATALOG

Please read and understand this catalog before purchasing the products. Please consult your OMRON representative if you have any questions or comments.

WARRANTY

OMRON's exclusive warranty is that the products are free from defects in materials and workmanship for a period of one year (or other period if specified) from date of sale by OMRON.

OMRON MAKES NO WARRANTY OR REPRESENTATION, EXPRESS OR IMPLIED, REGARDING NON-INFRINGEMENT, MERCHANTABILITY, OR FITNESS FOR PARTICULAR PURPOSE OF THE PRODUCTS. ANY BUYER OR USER ACKNOWLEDGES THAT THE BUYER OR USER ALONE HAS DETERMINED THAT THE PRODUCTS WILL SUITABLY MEET THE REQUIREMENTS OF THEIR INTENDED USE. OMRON DISCLAIMS ALL OTHER WARRANTIES, EXPRESS OR IMPLIED.

LIMITATIONS OF LIABILITY

OMRON SHALL NOT BE RESPONSIBLE FOR SPECIAL, INDIRECT, OR CONSEQUENTIAL DAMAGES, LOSS OF PROFITS OR COMMERCIAL LOSS IN ANY WAY CONNECTED WITH THE PRODUCTS, WHETHER SUCH CLAIM IS BASED ON CONTRACT, WARRANTY, NEGLIGENCE, OR STRICT LIABILITY.

In no event shall responsibility of OMRON for any act exceed the individual price of the product on which liability is asserted.

IN NO EVENT SHALL OMRON BE RESPONSIBLE FOR WARRANTY, REPAIR, OR OTHER CLAIMS REGARDING THE PRODUCTS UNLESS OMRON'S ANALYSIS CONFIRMS THAT THE PRODUCTS WERE PROPERLY HANDLED, STORED, INSTALLED, AND MAINTAINED AND NOT SUBJECT TO CONTAMINATION, ABUSE, MISUSE, OR INAPPROPRIATE MODIFICATION OR REPAIR.

SUITABILITY FOR USE

THE PRODUCTS CONTAINED IN THIS CATALOG ARE NOT SAFETY RATED. THEY ARE NOT DESIGNED OR RATED FOR ENSURING SAFETY OF PERSONS, AND SHOULD NOT BE RELIED UPON AS A SAFETY COMPONENT OR PROTECTIVE DEVICE FOR SUCH PURPOSES. Please refer to separate catalogs for OMRON's safety rated products.

OMRON shall not be responsible for conformity with any standards, codes, or regulations that apply to the combination of products in the customer's application or use of the product.

At the customer's request, OMRON will provide applicable third party certification documents identifying ratings and limitations of use that apply to the products. This information by itself is not sufficient for a complete determination of the suitability of the products in combination with the end product, machine, system, or other application or use.

The following are some examples of applications for which particular attention must be given. This is not intended to be an exhaustive list of all possible uses of the products, nor is it intended to imply that the uses listed may be suitable for the products:

- Outdoor use, uses involving potential chemical contamination or electrical interference, or conditions or uses not described in this document.
- Nuclear energy control systems, combustion systems, railroad systems, aviation systems, medical equipment, amusement machines, vehicles, safety equipment, and installations subject to separate industry or government regulations.
- Systems, machines, and equipment that could present a risk to life or property.

Please know and observe all prohibitions of use applicable to the products.

NEVER USE THE PRODUCTS FOR AN APPLICATION INVOLVING SERIOUS RISK TO LIFE OR PROPERTY WITHOUT ENSURING THAT THE SYSTEM AS A WHOLE HAS BEEN DESIGNED TO ADDRESS THE RISKS, AND THAT THE OMRON PRODUCT IS PROPERLY RATED AND INSTALLED FOR THE INTENDED USE WITHIN THE OVERALL EQUIPMENT OR SYSTEM.

PERFORMANCE DATA

Performance data given in this document is provided as a guide for the user in determining suitability and does not constitute a warranty. It may represent the result of OMRON's test conditions, and the users must correlate it to actual application requirements. Actual performance is subject to the OMRON Warranty and Limitations of Liability.

CHANGE IN SPECIFICATIONS

Product specifications and accessories may be changed at any time based on improvements and other reasons.

It is our practice to change model numbers when published ratings or features are changed, or when significant construction changes are made. However, some specifications of the product may be changed without any notice. When in doubt, special model numbers may be assigned to fix or establish key specifications for your application on your request. Please consult with your OMRON representative at any time to confirm actual specifications of purchased products.

DIMENSIONS AND WEIGHTS

Dimensions and weights are nominal and are not to be used for manufacturing purposes, even when tolerances are shown.

ERRORS AND OMISSIONS

The information in this document has been carefully checked and is believed to be accurate; however, no responsibility is assumed for clerical, typographical, or proofreading errors, or omissions.

PROGRAMMABLE PRODUCTS

OMRON shall not be responsible for the user's programming of a programmable product, or any consequence thereof.

COPYRIGHT AND COPY PERMISSION

This document shall not be copied for sales or promotions without permission.





This document is protected by copyright and is intended solely for use in conjunction with the product. Please notify us before copying or reproducing this document in any manner, for any other purpose. If copying or transmitting this document to another, please copy or transmit it in its entirety.

LED Safety

 WARNING
The Sensor emits visible light, which may adversely affect the eyes in rare instances. Do not look directly into the light emitted from the Sensor. When the subject is a specular reflective object, protect your eyes from reflected light.

Displaying LED Labels

Attached the enclosed warning label in a readily visible location near the product, such as on the cable.

 警告	 WARNIG
 LED放射 ビームの光線は鋭く Max.65mW 400-700nm クラス2 LED製品 JIS C 6802-2002	 LED RADIATION DO NOT STARE INTO BEAM Max.65mW 400-700nm CLASS 2 LED PRODUCT JIS C 6802-2002

Vision Series Lineup

The lineup covers everything from low-cost
Smart Cameras to highly customizable PC-based image processing systems.
Choose the best combination for your budget and needs.



Note: Do not use this document to operate the Unit.

OMRON Corporation Industrial Automation Company
Tokyo, JAPAN

Contact: www.ia.omron.com

Regional Headquarters

OMRON EUROPE B.V.
Sensor Business Unit
Carl-Benz-Str. 4, D-71154 Nufringen, Germany
Tel: (49) 7032-811-0/Fax: (49) 7032-811-199

OMRON ASIA PACIFIC PTE. LTD.
No. 438A Alexandra Road # 05-05/08 (Lobby 2),
Alexandra Technopark,
Singapore 119967
Tel: (65) 6835-3011/Fax: (65) 6835-2711

OMRON ELECTRONICS LLC
One Commerce Drive Schaumburg,
IL 60173-5302 U.S.A.
Tel: (1) 847-843-7900/Fax: (1) 847-843-7787

OMRON (CHINA) CO., LTD.
Room 2211, Bank of China Tower,
200 Yin Cheng Zhong Road,
PuDong New Area, Shanghai, 200120, China
Tel: (86) 21-5037-2222/Fax: (86) 21-5037-2200

Authorized Distributor:

© OMRON Corporation 2012 All Rights Reserved.
In the interest of product improvement,
specifications are subject to change without notice.

CSM_1_1_0812
Cat. No. Q193-E1-01

Printed in Japan
0812(0812)